

## Front Suspension:

**Ride Height:** \_\_\_\_\_  
**Camber:** \_\_\_\_\_  
**Toe:** \_\_\_\_\_  
**Anti-Roll Bar:** \_\_\_\_\_  
**Wheelbase Shim:** \_\_\_\_\_  
**Wheel Hex:** \_\_\_\_\_  
**Caster Block:**  
 7°  10°  13°   
**Notes:** \_\_\_\_\_  
 \_\_\_\_\_  
 \_\_\_\_\_  
 \_\_\_\_\_

**Axle Height:**  
 +3   
 +2   
 +1   
 0

**Arm Mount A:**  
 LRC  HRC  1°  0.5°



**Arm Mount B:**  
 LRC  HRC  1°  0.5°



**Bump Steer Spacing:** \_\_\_\_\_

**Ball Stud Spacing:** \_\_\_\_\_

**Steering Plate:** \_\_\_\_\_

**Ball Stud Spacing:** \_\_\_\_\_

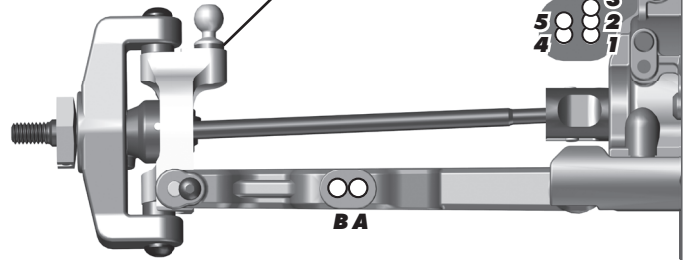

## Rear Suspension:

**Ride Height:** \_\_\_\_\_  
**Camber:** \_\_\_\_\_  
**Anti-Roll Bar:** \_\_\_\_\_  
**Wheelbase Shim:** \_\_\_\_\_  
**Wheel Hex:** \_\_\_\_\_  
**Hub Spacing:**  
 Forward  Middle  Back   
**Gearbox Shim:** Yes  No   
**Chassis Brace:** Short  Long   
**Notes:** \_\_\_\_\_  
 \_\_\_\_\_  
 \_\_\_\_\_

**Arm Mount C:**  
 LRC  HRC  1°  0.5°



**Arm Mount D:**  
 LRC  HRC  1°  0.5°



### Rear Hub Link Setting:

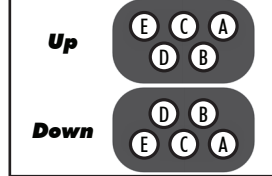

**Hub Insert:**  
 +3  +2  +1  0

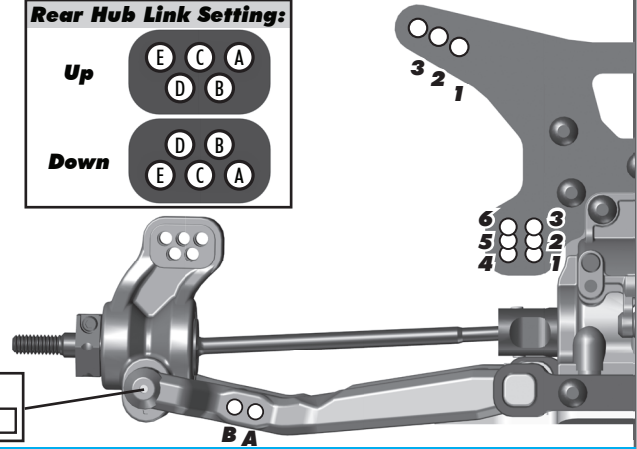

## Electronics:

**Radio:** \_\_\_\_\_ **Servo:** \_\_\_\_\_  
**EPA:** Throttle: \_\_\_\_\_ % Brake: \_\_\_\_\_ %  
**ESC:** \_\_\_\_\_  
**ESC Settings:** \_\_\_\_\_  
**Motor:** \_\_\_\_\_  
**Wind:** \_\_\_\_\_ **Timing:** \_\_\_\_\_  
**Pinion:** \_\_\_\_\_ **Spur:** \_\_\_\_\_  
**Battery:** \_\_\_\_\_  
**Battery Position:** \_\_\_\_\_

## Differential:

**Front Fluid:** \_\_\_\_\_  
**Gears:** Plastic  Metal   
**Center Fluid:** \_\_\_\_\_  
**Gears:** Plastic  Metal   
**Rear Fluid:** \_\_\_\_\_  
**Gears:** Plastic  Metal   
**Slipper Clutch:**  
**Type:** \_\_\_\_\_  
**# of Pads:** \_\_\_\_\_

## Shocks:

	Front	Rear
<b>Piston:</b>	_____	_____
<b>Fluid:</b>	_____	_____
<b>Spring:</b>	_____	_____
<b>Limiters:</b>	_____	_____
<b>Stroke:</b>	_____	_____
<b>Eyelet Length:</b>	_____	_____
<b>Cup Offset:</b>	_____	_____
<b>Notes:</b>	_____	_____



## Track Info:

**Size:** Small  Medium  Large  Extra Large   
**Surface:** Dirt  Carpet  AstroTurf  Multi Surface   
**Traction:** Low  Medium  High  Very High   
**Moisture:** Dry  Damp  Wet   
**Condition:** Indoor  Outdoor  Dusty  Hard Packed   
 Bumpy  Grooved  Smooth  Loamy   
**Temperature:** Ambient: \_\_\_\_\_ Track: \_\_\_\_\_  
**Notes:** \_\_\_\_\_

## Tires:

**Front Tires:** \_\_\_\_\_  
**Front Compound:** \_\_\_\_\_  
**Front Insert:** \_\_\_\_\_  
**Rear Tires:** \_\_\_\_\_  
**Rear Compound:** \_\_\_\_\_  
**Rear Insert:** \_\_\_\_\_  
**Wheel (F/R):** \_\_\_\_\_  
**Notes:** \_\_\_\_\_

## Body, Wing, Weight:

**Body:** \_\_\_\_\_  
**Wing:** \_\_\_\_\_  
**Wing Angle:** 0°  3°  6°   
**Chassis Weights:**  
 None  15g  30g  Other   
**Other Weights:** \_\_\_\_\_  
**Total Vehicle Weight:** \_\_\_\_\_

## Vehicle Comments:

**Notes:** \_\_\_\_\_